



Castegnato (BS), 19 maggio 2023

A tutti i Clienti,  
Loro sedi

### OGGETTO: Compatibilità tra materiali vetrata isolante

L'installazione di vetrate isolanti all'interno di un serramento implica un contatto tra il bordo della vetrata e diversi altri materiali, tra cui tasselli, sigillanti e guarnizioni.

**Tutti gli elementi a contatto con la sigillatura della vetrata isolante, per mantenerne inalterate le prestazioni, devono essere chimicamente compatibili con essa; aspetto purtroppo ampiamente sottovalutato e talvolta addirittura ignorato.** Due o più materiali sono tra loro compatibili quando le interazioni fisico-chimiche non creano danni al sistema nel tempo. Con la presente si ritiene di rinnovare l'attenzione su questa importante tematica.

L'utilizzo di materiali non compatibili con i sigillanti della vetrata isolante può innescare processi di migrazione e interazione chimica, un fenomeno a seguito del quale componenti dell'elemento incompatibile aggrediscono e penetrano la seconda barriera (polisolfuro/poliuretano/silicone) fino a raggiungere la prima barriera (butile), rendendola estremamente morbida ed elastica. Il butile dopo una volta "aggredito", cede, **invadendo l'intercapedine della vetrata e formando colature** più o meno evidenti. A parte il danno estetico, facilmente visibile, la migrazione comporta la perdita di isolamento dell'intercapedine, con conseguente fuori uscita del gas e ingresso del vapore acqueo; **compromettendo completamente la funzionalità della vetrata.** La velocità della reazione chimica può essere accelerata da temperature elevate, dall'esposizione solare e da gradienti marcati tra i materiali. Interazioni dannose possono avvenire anche tra intercalari ed elementi a contatto con essi, con conseguente alterazione del colore, formazione di bolle o delaminazione.

In seguito alcune fotografie di migrazione generata dal contatto tra vetrata isolante e silicone "neutro" non compatibile in battuta, e poliuretano espanso, nel secondo.





Esistono diverse norme che chiariscono ruoli e responsabilità nel processo di posa, tra cui la UNI EN 10818, la UNI EN 12488 e la UNI 11673. In tutte e tre le norme è esplicitato il concetto che la **“compatibilità tra i materiali deve essere controllata”**. La norma UNI 11673 mette in carico al progettista della posa in opera la verifica della compatibilità tra i vari elementi del sistema. Nel caso sia invece il posatore che opera senza specifici riferimenti, questo a tutti gli effetti si sostituisce al progettista, in termini operativi e di responsabilità.

**Per evitare danni alle vetrate isolanti consigliamo di verificare sempre con i vostri fornitori di sigillanti e componenti per la posa (tasselli, guarnizioni, fondi giunto, siliconi, nastri espandenti ecc.) la compatibilità di tutti gli elementi a contatto con il bordo del vetrocamera e dei vetri laminati.**

Le vetrate isolanti realizzate da Vetreria 2M impiegano come sigillanti:

1<sup>a</sup> barriera: Butile Butylver Fenzi.

2<sup>a</sup> barriera: Poliuretano Fenzi Poliver F o Silicone DOW 3363.

Alleghiamo in seguito schede tecniche e schede di compatibilità rilasciate dai produttori dei sigillanti da noi impiegati.

**VETRERIA 2M S.R.L.**

Via Cavezzo, 42 - 25045 - Castegnato - (BS)  
Tel. 030 6119575 - Fax 030 611866  
vetreria2m@vetreria2m.com - www.vetreria2m.com  
P.IVA - C.F. - R.I. BS 02749780983 Rea BS-47547  
Capitale sociale € 56.000,00 Int. Ver



Rev. 13  
Data: 31/03/2025

# BUTYLVER

“Sigillante butilico (prima-barriera) per vetrocamera”

## CAMPO DI APPLICAZIONE

- Sigillante monocomponente privo di solventi indicato per l'isolamento interno (prima-barriera) di vetrate isolanti. Minima permeabilità al vapore acqueo e ai gas, resistenza all'invecchiamento UV, buone proprietà adesive su vetro e metalli.

## DATI TECNICI

• BASE	Poliisobutilene.	
• COLORE	Nero.	
• CONSISTENZA	Massa solida, termoplastico (*).	
• VARIAZIONE IN VOLUME	Trascurabile.	UNI EN ISO 10563
• DENSITÀ (20 °C)	1.09 ± 0.03 [gr/cm <sup>3</sup> ]	EN ISO 1183-1
• PENETRAZIONE (60 °C)	50 – 65 [0.1 mm]	ISO 2137
• TRASMISSIONE DEL VAPOR D'ACQUA	< 0.1 [gr/m <sup>2</sup> ·d]	EN 1279-4
• PERMEABILITÀ AL GAS (Ar)	< 0.02 [gr/m <sup>2</sup> ·d]	EN 1279-4
• CONTENUTO VOLATILE (70 °C)	≤ 0.06 [%]	EN 1279-4
• CONDUTTIVITÀ TERMICA	0.20 [W/m·K]	EN 10077-2
• TEMPERATURE DI SERVIZIO	- 40 °C a + 70 °C	
• COMPATIBILITÀ	La compatibilità con tutti i materiali che possano venire a contatto diretto e/o indiretto with con Butylver, deve essere verificata prima dell'uso. Per maggiori dettagli contattare <a href="mailto:info@fenzigroup.com">info@fenzigroup.com</a> .	





Rev. 13  
Data: 31/03/2025

# BUTYLVER

## “Sigillante butilico (prima-barriera) per vetrocamera”

### APPLICAZIONE

- Le superfici di applicazione devono essere pulite, asciutte, prive di polveri e grassi. Il sigillante Butylver deve essere riscaldato fino a 120 °C – 150 °C prima di essere applicato mediante estrusori.

### CONSERVAZIONE

- In luogo fresco ed asciutto. Il sigillante Butylver in tali condizioni si conserva per almeno un anno.

### CLASSIFICAZIONE DEL PRODOTTO

- Prodotto non pericoloso ai sensi della normativa vigente. Richiedere SDS a [safety@fenzigroup.com](mailto:safety@fenzigroup.com).

### CONFEZIONI

- Disponibile in cilindri da 1 Kg. (Ø 99.6 mm), 2 Kg. (Ø 130 mm), 2.5 Kg. (Ø 143 mm) e 7 Kg. (Ø 190 mm).  
Disponibile in nastri Ø 1.7 mm (scatole da 22 rotoli, 55 m/cad).  
Disponibile in nastri 3.0 × 0.6 mm (scatole da 92 rotoli, 30 m/cad).  
Disponibile in fusti da 200 Kg.

### RESPONSABILITÀ DA PRODOTTO

(\*) Butylver è un sigillante con funzionalità termoplastica e, di conseguenza, movimenti del prodotto verso l'area di visibilità della vetrocamera sono possibili nel tempo, senza che questo comprometta le prestazioni del sistema. Questi movimenti possono essere causati dal tipo di progetto, dalle condizioni di installazione e da fattori esterni quali clima, carichi del vento e differenze di pressione. Il Gruppo FENZI non si assume alcuna responsabilità per questo tipo di irregolarità puramente estetiche.



# POLIVER F

“Sigillante poliuretano bi-componente per vetrocamera”

## CAMPO DI APPLICAZIONE

- I sigillanti Poliver F sono poliuretani specificatamente formulate per la fabbricazione di vetrate isolanti. I sigillanti Poliver F sono prodotti in diversi tipi per meglio adattarsi alle single esigenze degli operatori e degli impianti utilizzati. I sigillanti Poliver F sono completamente esenti da solvente e possono essere utilizzati per la produzione di doppi e tripli pannelli.

## CARATTERISTICHE TECNICHE

- |                                   |   |   |
|-----------------------------------|---|---|
| • <b>COLORE/ASPETTO</b>           | Parte A (base):<br>Parte B (catalizzatore):<br>Miscela (A+B): | Beige/Pastoso<br>Nero/Liquido o Pastoso<br>Antracite/Pastoso, non cola  |
| • <b>RAPPORTO DI MISCELAZIONE</b> | Rapporto in volume:<br>Rapporto in peso:<br>Rapporto in peso: | 100 : 10<br>100 : 7.1 per catalizzatore liquido<br>100 : 6.8 per catalizzatore pastoso  |
| • <b>TOLLERANZA MISCELAZIONE</b>  |   | ± 15 %  |
| • <b>TEMPO DI LAVORABILITÀ</b>    |   | Standard 15-90 minuti.<br>Il tempo di lavorabilità varia in funzione delle condizioni ambientali.   |
| • <b>TEMPO DI INDURIMENTO</b>     |   | ca. 3-6 ore in funzione delle condizioni ambientali.  |
| • <b>ADERENZA</b>                 |   | Eccellente su materiali come vetro, alluminio, acciaio inossidabile, acciaio galvanizzato. La superficie di applicazione deve essere pulita, asciutta ed esente da grassi.  |
| • <b>CONDUTTIVITÀ TERMICA</b>     | 0.40 [W/m·K]  | EN 10077-2  |
| • <b>TEMPERATURE DI SERVIZIO</b>  |   | - 40 °C a + 70 °C   |
| • <b>COMPATIBILITÀ</b>            |   | La compatibilità di tutti I materiali che possano eventualmente venire a contatto diretto con il Poliver F deve essere verificata prima dell'uso. Per maggiori dettagli consultare <a href="mailto:info@fenzigroup.com">info@fenzigroup.com</a> . |





# POLIVER F

“Sigillante poliuretano bi-componente per vetrocamera”

## CARATTERISTICHE CHIMICO-FISICHE

● VISCOSITÀ (25 °C)	Parte A (base)	60 - 95 [Pa*s]	PP Ø 25 mm, 45 s <sup>-1</sup>
● DENSITÀ (20 °C)	Part A (base)	1,75 ± 0,05 [gr/cm <sup>3</sup> ]	EN ISO 1183-1 (pastoso) (liquido)
	Part B (catalizzatore)	1,23 ± 0,05 [gr/cm <sup>3</sup> ]	
		1,19 ± 0,05 [gr/cm <sup>3</sup> ]	
● DUREZZA FINALE		min. 45 [Shore A]	EN 1279/6
● TASSO DI TRASMISSIONE DEL VAPOR D'ACQUA		3.5 [gr/m <sup>2</sup> ·d]	EN 1279/4
● TASSO DI PERMEAZIONE DEL GAS (Ar)		1.00 [gr/m <sup>2</sup> ·d]	EN 1279/4
● ALLUNGAMENTO A ROTTURA		ca. 30 [%]	EN 1279/4
● CARICO DI ROTTURA		ca. 0.80 [MPa]	EN 1279/4
● CARICO (AB)		0.37 [MPa] ± 20 %	EN 1279/4
● CONTENUTO VOLATILE A+B (70 °C)		Max. 1 [%]	EN 1279/4

● DURATA A MAGAZZINO 9 mesi negli imballi originale. Possibilmente in luogo fresco ed asciutto ad una temperatura da +10 °C a +30 °C.

● CLASSIFICAZIONE DEL PRODOTTO Richiedere SDS a [safety@fenzigroup.com](mailto:safety@fenzigroup.com)

● CONFEZIONI

Parte A:	191	Lt	335	Kg netto
Parte B:	19,1	Lt	23,5	Kg netto (pastoso)
	191	Lt	235	Kg netto (pastoso)
	19,1	Lt	23	Kg netto (liquido)
	191	Lt	230	Kg netto (liquido)

● PULIZIA IMPIANTI Utilizzare preferibilmente KR 6550 solvente per poliuretani, un prodotto del Gruppo FENZI. Contattare Assistenza Tecnica.

FENZI		Compatible Sealants with Thiover/Butylver and Poliver F/Butylver			
Testing period	SEALANT	Base	Company	Curing	Approval
2025 1st quarter	Profect® Bond & Seal SG60S, light grey	Silicone	Dana Lim	neutral	IFT
2025 1st quarter	Profect® 11801 SG20S, black	Silicone	Dana Lim	neutral	IFT
2025 1st quarter	Profect® 11801 SG20S, transparent	Silicone	Dana Lim	neutral	IFT
2022 2nd quarter	Danaseal Construction 515, transparent	Silicone	Dana Lim	neutral alcoxy	IFT
2025 1st quarter	Danaseal sanitary & build silicone 514, transparent	Silicone	Dana Lim	neutral	IFT
2025 2nd quarter	Parasilico Monument, black	Silicone	DL Chemicals	neutral alcoxy	IFT
2022 2nd quarter	Parasilico FR, grey	Silicone	DL Chemicals	neutral alcoxy	IFT
2025 2nd quarter	Parasilico Alcoxy 15 T, transparent	Polysiloxane	DL Chemicals	neutral alcoxy	IFT
2025 2nd quarter	Parasilico Alcoxy 15, white	Polysiloxane	DL Chemicals	neutral alcoxy	IFT
2025 2nd quarter	Parasilico VP, white	Polysiloxane	DL Chemicals	neutral alcoxy	IFT
2022 4th quarter	Parasilico Curtain Wall, black	Silicone alkoxy	DL Chemicals	neutral alcoxy	IFT
2025 2nd quarter	Parasilico Pro Glass, white	Polysiloxane	DL Chemicals	neutral alcoxy	IFT
2025 2nd quarter	Parasilico Pro Glass T, transparent	Polysiloxane	DL Chemicals	neutral alcoxy	IFT
2025 4th quarter	Dowsil 895, black	Silicone	Dow	neutral	IFT
2024 4th quarter	Dowsil 791 Weatherproofing Sealant	Silicone	Dow	neutral	IFT
2024 2nd quarter	Dowsil 791, white	Silicone	Dow	neutral	IFT
2024 2nd quarter	Dowsil 791, grey	Silicone	Dow	neutral	IFT
2024 2nd quarter	Dowsil 791, black	Silicone	Dow	neutral	IFT
2023 3rd quarter	Dowsil 796, black	Silicone	Dow	neutral	IFT
2023 2nd quarter	Dowsil 799 EU Glaze and Go, transparent	Silicone	Dow	neutral	IFT
2021 1st quarter	Dowsil 776 Instantfix WB, black	Hybrid Polymer	Dow	neutral	IFT
2023 2nd quarter	Dowsil 895, black	Silicone	Dow	neutral	IFT
2023 2nd quarter	Fenster & Anschluss HPF, transparent	Silicone	EVT	neutral	IFT
2021 1st quarter	2H SIL RC	Silicone	Heller	neutral	IFT
2021 4th quarter	Koediglaze P, grey	Polyurethane 2K	Koemmerling	moisture	IFT
2021 4th quarter	Ottoseal S120, black	Silicone alkoxy	Otto Chemie	moisture	IFT
2022 2nd quarter	Ottoseal S112, transparent	Silicone	Otto Chemie	neutral	IFT
2022 2nd quarter	Ottoseal S110, black	Silicone	Otto Chemie	neutral (oxime)	IFT
2021 2nd quarter	Ottoseal S 7, black	Silicone	Otto Chemie	neutral	IFT
2023 1st quarter	Ottocoll S 81, black	Silicone 2K	Otto Chemie	neutral	IFT
2023 1st quarter	Ottocoll S 88, black	Silicone	Otto Chemie	neutral	IFT
2022 2nd quarter	350 Fassade, black	Silicone	Ramsauer	neutral	IFT
2024 4th quarter	Sikasil WT-470, black	Silicone 2K	Sika	polycondensation	IFT
2024 4th quarter	Sikasil WT-480, black	Silicone 2K	Sika	polycondensation	IFT
2024 4th quarter	Sikasil WT-485, black	Silicone 2K	Sika	polycondensation	IFT
2026 1st quarter	Sikasil WT-40, black	Silicone	Sika	neutral	IFT
2021 2nd quarter	Sikasil SG-20, black	Silicone	Sika	neutral	IFT
2022 4th quarter	Sikasil SG-20, white	Silicone	Sika	neutral	IFT
2021 2nd quarter	Sikasil SG-500, black	Silicone 2K	Sika	moisture	IFT
2026 1st quarter	Sikasil WS-605 S	Silicone	Sika	neutral	IFT
2025 4th quarter	Silirub 2	Silicone	Soudal	neutral	IFT
2025 2nd quarter	Silirub N07, transparent	Silicone	Soudal	neutral	IFT

**LEGENDA:** IFT = Approved according to IFT ROSENHEIM RICHTLINIE DI-01/01 Triple Test (THREE TEST P1 4.1)  
 RAL-IFT = Approved according to GÜTESICHERUNG RAL-GZ 716/1 (May 2009) and IFT  
 testing period in bold: up to one year tested  
 testing period in grey: more than 4 years tested

**VALIDITY:** Compatibility statement of tested materials is valid for 5 years from testing period

**DISCLAIMER:** Compatibility statement is valid only for tested materials. Since we have no control over the manufacture or formulation of these materials, Fenzi S.p.A. makes no guarantee of results and assumes no liability for damages occurred by following these suggestions. This Compatibility statement is valid only in case of Standard Window Glazing. The trademark is the exclusive property of Fenzi S.P.A. and its use, even partial, for advertising, promotional, or similar activities is prohibited without the prior written consent of the owner.



## **DOWSIL™ 3363 Insulating Glass Sealant**

Two-part silicone sealant with high strength for use as a secondary seal in insulating glass units.

### **Features & Benefits**

- Economical joint sizes in high strength IG applications
- High design strength (0.21 MPa) allowing joint size reduction up to 30%
- Enhanced productivity with reduced joint dimensions
- European Technical Approval (ETA13/0359)
- Suitable for gas-filled triple glazed units and gas-filled double glazed units
- Structural capability as secondary sealant for insulating glass in structural glazing applications
- Outstanding adhesion to a wide range of substrates including coated and reflective glasses, aluminum and steel spacers, and a variety of plastics
- Meets EN 1279 part 4 and 6 and EN 13022
- Tested according to EN 15434
- Meets the requirements of CEKAL
- Low water absorption
- Excellent temperature stability: -50°C to 150°C
- Non-corrosive cure
- Fast curing time
- Outstanding resistance to ozone and ultraviolet (UV) radiation
- High modulus which limits the stress on the primary sealant and makes it particularly suited for gas-filled insulating glass units

### **Applications**

- DOWSIL™ 3363 Insulating Glass Sealant is a high strength secondary two-part silicone sealant specifically designed for high strength applications, where conventional sealants with lower strength would lead to increased joint sizes. It enables economical joint sizes in highly demanding insulating glass (IG) applications such as: high wind in tall buildings, hurricane loads, cold-bent glass or high impact loads such as bomb blast. Smaller joint dimensions can be filled faster and therefore lead to productivity enhancements.
- DOWSIL™ 3363 Insulating Glass Sealant is ideal as a secondary sealant for triple and double glazed units and meets EN 1279 requirements for gas-filled IG.
- DOWSIL™ 3363 Insulating Glass Sealant can be used in IG applications for structurally glazed facades. It is UV resistant, provides long-term durability and excellent adhesion to glass and IG spacers.

## Typical Properties

Specification Writers: These values are not intended for use in preparing specifications.

Test <sup>1</sup>	Property	Unit	Result
<b>DOWSIL™ 3363 Insulating Glass Sealant Base: as supplied</b>			
	Color and consistency		White, viscous paste
	Specific gravity		1.38
<b>DOWSIL™ 3363 Insulating Glass Sealant Curing Agent: as supplied</b>			
	Color and consistency		Thick black paste
	Specific gravity		1.05
	Viscosity (60 s <sup>-1</sup> )	Pa.s	7.5
<b>As mixed</b>			
	Color and consistency		Black non-slump paste
	Working time (25°C, 50% R.H.)	minutes	5–10
	Snap time (25°C, 50% R.H.)	minutes	10–30
	Specific gravity		1.33
	Corrosiveness		Non-corrosive
ISO 8339	Tensile strength	MPa	1.5
EN 1279-6	Durometer hardness, Shore A		60
ETAG 002	Design stress in tension	MPa	0.21
	Design stress in static shear	MPa	0.011
	Elastic modulus in tension or compression	MPa	4.8
EN 1279-4	Water vapor permeability (2.0 mm film)	g/m <sup>2</sup> /24h	18
EN 1279-4	Gas permeability	g/(m <sup>2</sup> h)	0.46

1. ISO: International Standardization Organization  
 EN: European Norm  
 ETAG: European Technical Agreement Guidelines

### Description

DOWSIL™ 3363 Insulating Glass Sealant is a two-part, neutral curing silicone formulation for insulating glass applications.

### Technical Specifications and Standards

DOWSIL™ 3363 Insulating Glass Sealant is suitable as secondary seal in gas-filled insulating glass units and meets the requirements according to EN 1279 in an IG system. It is suitable for gas-filled triple and double glazed IG. As valid for any other technology, a proper application and fabrication of the insulating glass unit is required.

DOWSIL™ 3363 Insulating Glass Sealant is CE-marked according to ETAG002. The product also meets requirements according to EN 1279 parts 4 and 6.

SNJF Vi-VEC



**Technical Specifications and Standards (Cont.)**

Meets the requirements of CEKAL.



RAL Quality Label 520/2-3

Regulation or protocol	Conclusion	Version of regulation or protocol
French VOC régulations	A+	Regulation of March and May 2011 (DEVL1101903D and DEVL1104875A)
French CMR components	Pass	Regulation of April and May 2009 (DEVP0908633A and DEVP0910046A)
AgBB/ABG	Pass	Anforderungen an bauliche Anlagen bezOglich des Gesundheitsschutzes (ABG), Entwurf 31.08.2017/August 2018 (AgBB)
Belgian Regulation	Pass	Royal decree of May 2014 (C-2014/24239)
EMICODE	EC 1 Plus	April 2019
Indoor Air Comfort	Pass	Indoor Air Comfort 6.0 of February 2017
Indoor Air Comfort GOLD	Pass	Indoor Air Comfort GOLD 6.0 of February 2017
BREEAM International	Compliant	BREEAM International New Construction v2.0 (2016)
BREEAM Norway	Pass	BREEAM-NOR New Construction v1.2 (2019)
CDPH	Pass	
M1	Pass	

**How to Use**

**Mixing and Dispensing Instructions**

DOWSIL™ 3363 Insulating Glass Sealant should be mixed in a ratio of 10:1 base to curing agent by weight. At this mix ratio, the sealant typically exhibits a working time of 5–10 minutes and allows units to be handled within two hours. Slight variations in mixing ratio can be tolerated, but these should not exceed 11:1 to 9:1 by weight to ensure minimum properties are obtained.

The sealant is compatible with most of DOWSIL™ neutral curing sealants. Please contact our technical services department for more information.

**How to Use (Cont.)****Mixing and Dispensing Instructions (Cont.)**

To achieve the best mechanical properties of DOWSIL™ 3363 Insulating Glass Sealant, it is recommended that the base and curing agent are thoroughly mixed using an airless mixing system found on most existing commercially available two-part silicone dispensing machines.

**Equipment Cleaning**

When not being used it is recommended that the dispensing equipment be purged either with the uncatalyzed base, or flushed with a suitable solvent such as DOWSIL™ 3522 Cleaning Solvent Concentrated. If cured sealant has built up inside the equipment it is recommended to flush the equipment for the appropriate time with DOWSIL™ 3522 Cleaning Solvent Concentrated. This solvent dissolves cured silicone sealant and provides optimum cleaning performance.

**Handling  
Precautions**

PRODUCT SAFETY INFORMATION REQUIRED FOR SAFE USE IS NOT INCLUDED IN THIS DOCUMENT. BEFORE HANDLING, READ PRODUCT AND SAFETY DATA SHEETS AND CONTAINER LABELS FOR SAFE USE, PHYSICAL AND HEALTH HAZARD INFORMATION. THE SAFETY DATA SHEET IS AVAILABLE ON THE DOW WEBSITE AT DOW.COM, OR FROM YOUR DOW SALES APPLICATION ENGINEER, OR DISTRIBUTOR, OR BY CALLING DOW CUSTOMER SERVICE.

**Usable Life and  
Storage**

When stored at or below 30°C, DOWSIL™ 3363 Insulating Glass Sealant Curing Agent has a usable life of 14 months from the date of production.

When stored at or below 30°C, DOWSIL™ 3363 Insulating Glass Sealant Base has a usable life of 14 months from the date of production.

**Packaging  
Information**

Lot matching of DOWSIL™ 3363 Insulating Glass Sealant Base and DOWSIL™ 3363 Insulating Glass Sealant Curing Agent is not required. DOWSIL™ 3363 Insulating Glass Sealant Base is available in 250 kg drums. DOWSIL™ 3363 Insulating Glass Sealant Catalyst is available in 25 kg pails.

**Limitations**

The sealant cannot be used for structural glazing of glass units onto a metal frame. DOWSIL™ 993 SG Sealant is the recommended product for that application. Please contact Dow to get the proper glazing recommendations when using coated glass.

This product is neither tested nor represented as suitable for medical or pharmaceutical uses.

**Health and  
Environmental  
Information**

To support customers in their product safety needs, Dow has an extensive Product Stewardship organization and a team of product safety and regulatory compliance specialists available in each area.

For further information, please see our website, [dow.com](http://dow.com) or consult your local Dow representative.

## Disposal Considerations

Dispose in accordance with all local, state (provincial) and federal regulations. Empty containers may contain hazardous residues. This material and its container must be disposed in a safe and legal manner.

It is the user's responsibility to verify that treatment and disposal procedures comply with local, state (provincial) and federal regulations. Contact your Dow Technical Representative for more information.

## Product Stewardship

Dow has a fundamental concern for all who make, distribute, and use its products, and for the environment in which we live. This concern is the basis for our product stewardship philosophy by which we assess the safety, health, and environmental information on our products and then take appropriate steps to protect employee and public health and our environment. The success of our product stewardship program rests with each and every individual involved with Dow products - from the initial concept and research, to manufacture, use, sale, disposal, and recycle of each product.

## Customer Notice

Dow strongly encourages its customers to review both their manufacturing processes and their applications of Dow products from the standpoint of human health and environmental quality to ensure that Dow products are not used in ways for which they are not intended or tested. Dow personnel are available to answer your questions and to provide reasonable technical support. Dow product literature, including safety data sheets, should be consulted prior to use of Dow products. Current safety data sheets are available from Dow.

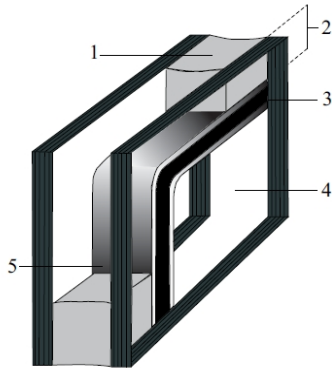

### Legend

1. Secondary seal (DOWSIL™ 3363 Insulating Glass Sealant)
2. Secondary seal - sealant depth
3. Primary seal – polyisobutylene
4. Glass
5. Spacer bar

**Figure 1:** Typical section of a dual sealed insulating glass unit.

dow.com

**NOTICE:** No freedom from infringement of any patent owned by Dow or others is to be inferred. Because use conditions and applicable laws may differ from one location to another and may change with time, Customer is responsible for determining whether products and the information in this document are appropriate for Customer's use and for ensuring that Customer's workplace and disposal practices are in compliance with applicable laws and other government enactments. The product shown in this literature may not be available for sale and/or available in all geographies where Dow is represented. The claims made may not have been approved for use in all countries. Dow assumes no obligation or liability for the information in this document. References to "Dow" or the "Company" mean the Dow legal entity selling the products to Customer unless otherwise expressly noted. NO WARRANTIES ARE GIVEN; ALL IMPLIED WARRANTIES OF MERCHANTABILITY OR FITNESS FOR A PARTICULAR PURPOSE ARE EXPRESSLY EXCLUDED.





High Performance Building Solutions

## **Dow Construction Industry System Sealant Compatibility Statement**

**Date:** 8th January 2022

**To :** Whom it concerns

**Subject:** Compatibility

Based on and within the limits of the test results from ASTM C-1087 test procedure or test method ETAG 002 Paragraph 5.1.4.2.5 (long term compatibility through qualitative adhesion test), we confirm that

Dow Sil™ 993 Structural Glazing Sealant,  
Dow Sil™ 993N Structural Glazing Sealant,  
DowSil™ 994 Ultra Fast Windows Bonding Sealant,  
Dow Sil™ 895 Structural Glazing Sealant,  
Dow Sil™ 995 Structural Glazing Sealant,  
Dow Sil™ 3362 Insulating Glass Sealant,  
Dow Sil™ 3362HD Insulating Glass Sealant,  
Dow Sil™ 3362N Insulating Glass Sealant,  
Dow Sil™ 3363 Insulating Glass Sealant,  
Dow Sil™ 3441 Two-Part Fast Cure Workshop Silicone,  
Dow Sil™ 3793 Insulated Glass Sealant,  
Dow Sil™ 983 Structural Glazing Sealant  
DOWSIL™ 982 Silicone Insulating Glass Sealant  
DOWSIL™ 121 Structural Glazing Sealant  
DOWSIL™ 3545 Insulating Glass Sealant  
Dow Sil™ 791 Silicone Weatherproofing Sealant,  
Dow Sil™ 797 Silicone Weatherproofing Sealant  
Dow Sil™ 796 PVC-U, Aluminium & Wood Silicone,  
DowSil™ 817 Mirror Adhesive  
DowSil™ 896 PanelFix  
DowSil™ 756 SMS Building Sealant  
DowSil™ 776 InstantFix WB  
DowSil™ 813C Construction & Concrete Silicone Sealant  
DowSil™ 791T Weatherproof Silicone Sealant  
DowSil™ 3-0117 Silicone Insulating Glass Sealant  
DowSil™ 799 EU Glaze & Go Sealant  
DowSil™ 795 Silicone Building Sealant  
DowSil™ Firestop 700  
DowSil™ C60 Low Modulus Silicone Sealant  
DowSil™ 335 Butyl Sealant  
DowSil™ FIRESTOP 400 Sealant  
DOWSIL™ SmokeSeal 800 SL



## High Performance Building Solutions

---

are compatible together.

For more information and assistance in product selection, please contact your Dow Construction Sales Application Engineer or your Dow Technical Service Engineer.

Best regards,

A handwritten signature in black ink, appearing to read "S. Dath", written over a horizontal line.

Sebastien Dath  
Façade Engineering & Architectural Design Manager - EMEAI  
High Performance Building